

cMT-iPC10 series

Installation Instruction

1 Installation and Startup Guide

This document covers the installation of cMT-iPC10, for the detailed specifications and operation, please refer to Brochure and User Manual.

Install Environment:

NEMA Rating	The cMT-iPC10 Series HMI is NEMA 4 rated.
Electrical Environment	The cMT-iPC10 Series has been tested to conform to European CE requirements. This means that the circuitry is designed to resist the effects of electrical noise. This does not guarantee noise immunity in severe cases. Proper wire routing and grounding will insure proper operation.
Environmental Considerations	<ol style="list-style-type: none"> (1) Make sure that the units are installed correctly and that the operating limits are followed. Avoid installing units in environments where severe mechanical vibration or shocks are present. (2) Do not operate the unit in areas subject to explosion hazards due to flammable gases, vapors or dusts. (3) Do not install the unit where acid gas, such as SO₂ exists. (4) This device should be mounted in the vertical position and for use on the flat surface enclosure. (5) Conform to UL508 (ISBN 0-7629-0404-6) machine safety for use in Pollution Degree 2 Environment.

2 Unpacking the Unit

Unpack and check the delivery. If damage is found, notify the supplier.

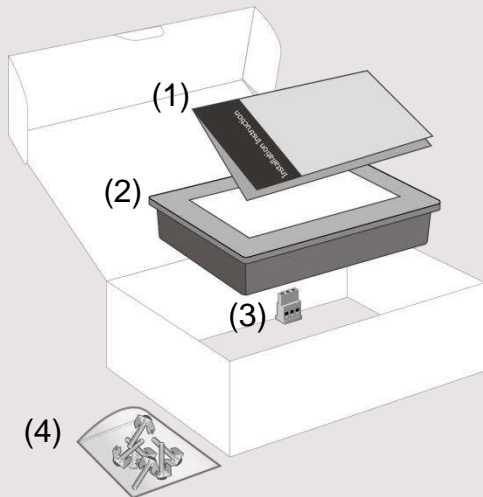

(1) Installation Instruction, 2-sided A4 *1

(2) Human Machine Interface *1

(3) Power Connector *1

(4) Brackets & Screws *1 pack

NOTE:

Place the unit on a stable surface during installation. Dropping it or letting it fall may cause damage.

3 Installation Instructions

Secure the operator panel in position, using all the fastening holes and the provided brackets and screws. Screw Torque: 2.6 ~ 3.9 lbf.in. (For reaching waterproof effect and preventing the panel from being deformed.)

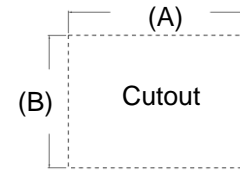

Type	A(mm)	B(mm)
cMT-iPC10	250	192

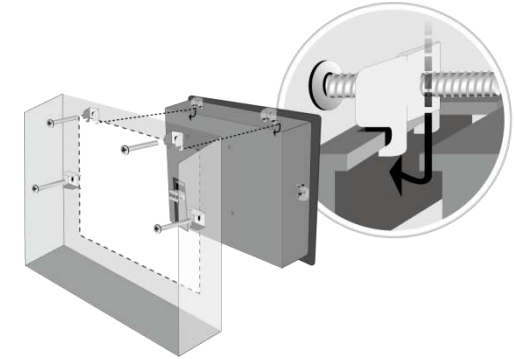

4 Power Connections



NOTE:

1. Connect positive DC line to the '+' terminal and the DC ground to the '-' terminal.

5 BIOS Settings

Ways to enter BIOS:

Way 1: Connect a USB keyboard and press F2 Key at startup.

Way 2: Press and hold one of the four corners of the screen at startup.

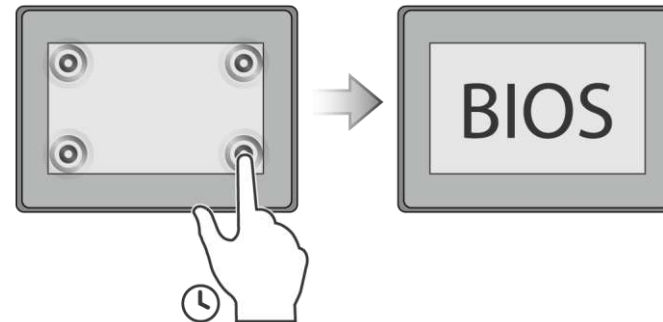

6 Installing Windows OS

1. Read the Windows installation disc by connecting a USB CD-ROM drive.
(Or, burn the Windows ISO image to a USB drive, and then insert the USB drive into HMI.)
2. Press and hold on the center of the screen and then select the device.
(Or, connect a USB keyboard, and press F5 key at startup.)

7 Turning ON/OFF the HMI

ON:

To turn on the HMI, go to BIOS and set whether to automatically turn on, or press the power button to turn on, when the HMI is connected to power supply.

Go to BIOS \ Advanced \ South Cluster Configuration \ Miscellaneous Configuration \ State After G3:

S0 State: Automatically turn on when connected to power supply.

S5 State: Press the power button to turn on when connected to power supply.

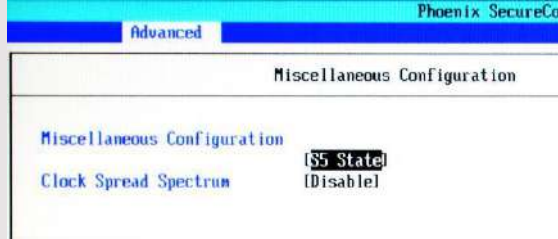

OFF:

To turn off the HMI, you can either turn off in Windows, or set the function of the power button in Windows Control Panel \ System and Security \ Power Options \ Change what the power buttons do, and press the power button when HMI is ON.

⚠ Unplugging power cord directly can cause stop error and lead to data loss.

8 Driver

After installing Windows OS, install the required software / hardware drivers, in the same order as listed in the following link.

Download Link: http://www.weintek.com/Download/cMT/cMT_iPC10/driver/cMT_iPC10_driver.htm

9 Touchscreen Calibration

To do touchscreen calibration, run HIDEGalaxTouch Tool.

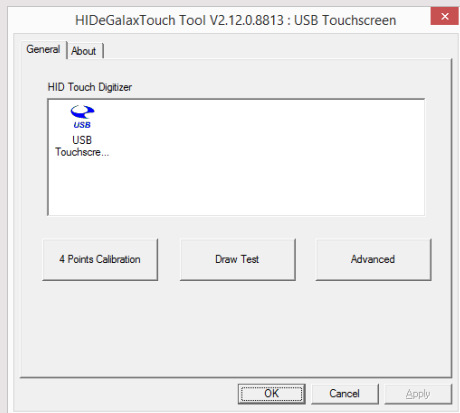

CAUTION

NOTE: Make sure that all local and national electrical standards are met when installing the unit. Contact your local authorities to determine which codes apply.



Power

The unit can be powered by DC power only, voltage range: 24±20% Volts DC, compatible with most controller DC systems. The power conditioning circuitry inside the unit is accomplished by a switching power supply. The peak starting current can be as high as 4A.

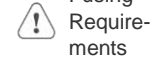

Fusing Requirements

If the display does not come on within 5 seconds of power up, remove power. A resettable fuse will protect against overcurrent faults in DC circuit and the resetting will take place after a period of time. Check wiring for proper connections and try to power up again.

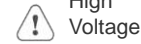

High Voltage

A resettable fuse will prevent damage for overcurrent condition however it isn't guaranteed. DC voltage sources should provide proper isolation from main AC power and similar hazards.



Emergency Stop

A Hard-wired EMERGENCY STOP should be fitted in any system using a HMI to comply with ICS Safety Recommendations.



Supply Voltage Condition

Do not power the unit and inductive DC loads, or input circuitry to the controller, with the same power supply. Note: The 24 VDC output from some controllers may not have enough current to power the unit.



Wire Routing

- a. Power wire length should be minimized (Max: 500m shielded, 300m unshielded).
- b. Please use twisted pair cables for power wire and signal wire and conform to the impedance matching.
- c. If wiring is to be exposed to lightning or surges, use appropriate surge suppression devices.
- d. Keep AC, high energy, and rapidly switching DC power wiring separated from signal wires.
- e. Add a resistor and capacitor in the parallel connection between the ungrounded DC power supply and the frame ground. This provides a path for static and high frequency dissipation. Typical values to use are 1M Ohm and 4700pF.

DANGER

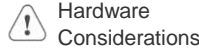

Hardware Considerations

The system designer should be aware that devices in Controller systems could fail and thereby create an unsafe condition. Furthermore, electrical interference in an operator interface can lead to equipment start-up, which could result in property damage and/or physical injury to the operator. If you use any programmable control systems that require an operator, be aware that this potential safety hazard exists and take appropriate precautions. Although the specific design steps depend on your particular application, the following precautions generally apply to installation of solid-state programmable control devices, and conform to the guidelines for installation of Controllers recommended in NEMA ICS 3-304 Control Standards.

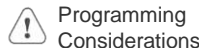

Programming Considerations

To conform with ICS Safety Recommendations, checks should be placed in the controller to ensure that all writable registers that control critical parts of plant or machinery have limit checks built into the program, with an out-of-limit safe shut down procedure to ensure safety of personnel.

GMECM100_cMT_iPC10_Installation_161018

Limited Warranty

This product is limited warranted against defects in design and manufacture. The proven defective product will either be repaired or replaced, at Weintek's discretion. This warranty shall not cover any product which is

- (a) Out of warranty period which is 12 months from the manufacturing month of the HMI products.
- (b) Damage caused by Force Majeure, accident, negligence, improper installation or misuse.
- (c) Product has been repaired or taken apart by unauthorized technicians.
- (d) Products whose identification markings have been removed or damaged.