

Haiwell PLC User Manual

A Series Card-type PLC

PLC MPU User Manual

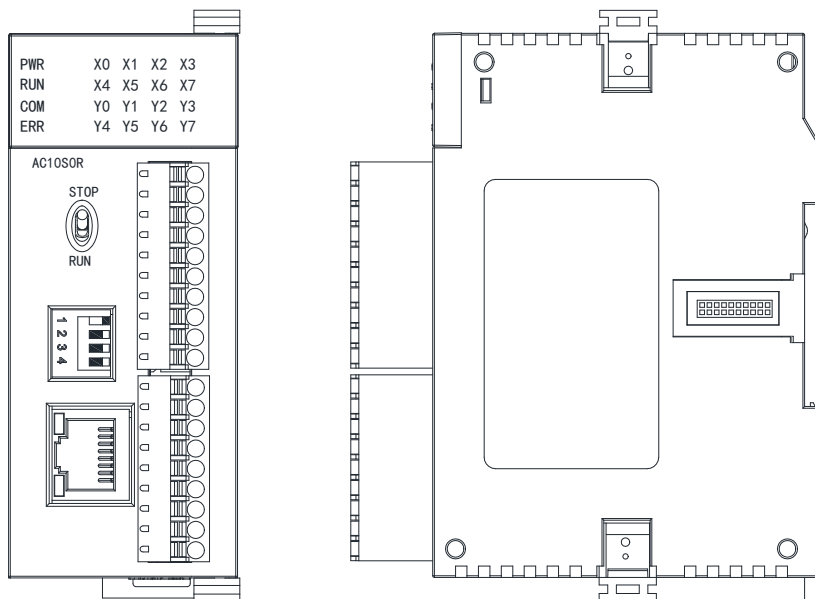

Contents

1. Product Model List & Dimensions.....	3
2. Indicator Description.....	4
3. Power Supply Specification.....	4
4. Environmental specifications for Product.....	4
5. Digital Input (DI) Specification.....	4
6. Digital Output (DO) Specification.....	5
7. Analog Input (AI) Specification.....	5
8. Analog Output (AQ) Specification.....	5
9. Digital Input/Output (DI/DO) Wiring.....	5
10. Analog Input (AI) Wiring Diagram.....	6
11. Analog Output (AQ) Wiring Diagram.....	6
12. MPU Terminal Wiring Diagram.....	6
13. PLC Mounting and installation.....	6
14. Address Setting.....	7
15. Power Supply Wiring.....	7

1. Product Model List & Dimensions

AC/AT/AH Series Model List & Dimensions

AC series models	Power Consumption(24VDC)	Dimension(W × H × D)
AC10S0R	DC24V~0.2A MAX	40×95×65mm
AC10S0T	DC24V~0.2A MAX	
AC10S0P	DC24V~0.2A MAX	
AC16S0R	DC24V~0.2A MAX	
AC16S0T	DC24V~0.2A MAX	
AC16S0P	DC24V~0.2A MAX	
AC12M0R	DC24V~0.15A MAX	
AC12M0T	DC24V~0.15A MAX	
AC12M0P	DC24V~0.15A MAX	

AT series models	Power Consumption(24VDC)	Dimension(W × H × D)
AT16S0R	DC24V~0.2A MAX	40×95×65mm
AT16S0T	DC24V~0.2A MAX	
AT16S0P	DC24V~0.2A MAX	
AT12M0R	DC24V~0.15A MAX	
AT12M0T	DC24V~0.15A MAX	
AT12M0P	DC24V~0.15A MAX	

AH series models	Power Consumption(24VDC)	Dimension(W × H × D)
AH16S0R	0.2A MAX	40×95×65mm
AH16S0T	0.2A MAX	
AH16S0P	0.2A MAX	

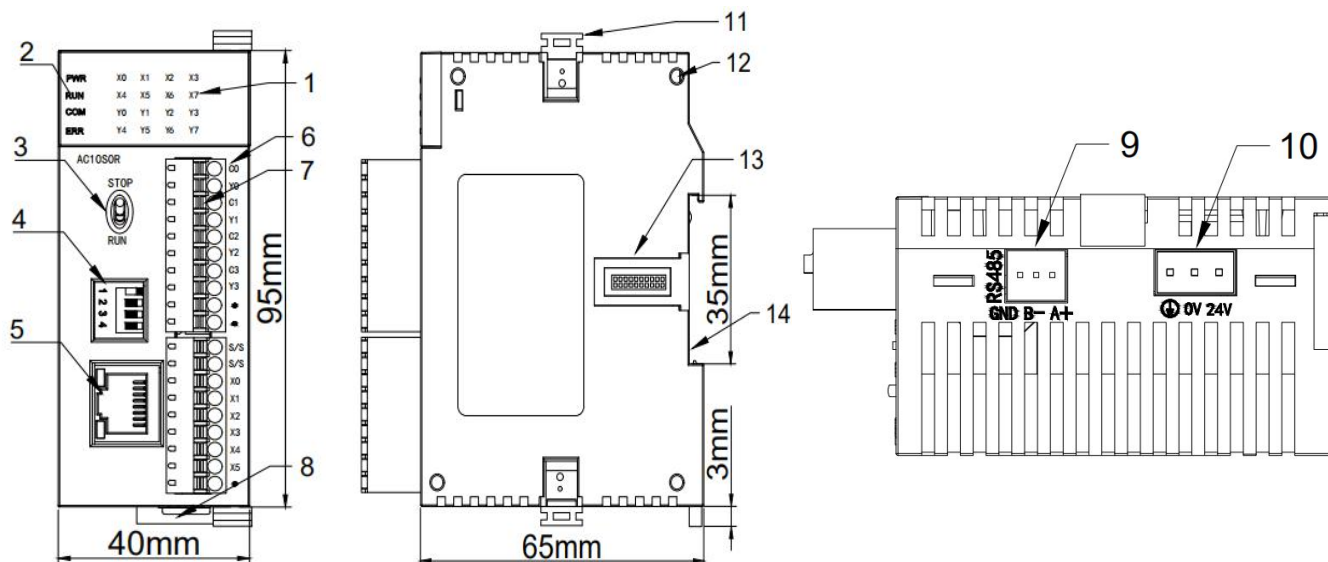

1. Digital channel indicator 1. PWR:Power indicator, RUN:Running indicator, COM:Communication indicator, ERR:Error indicator	8. Rail clip
2. Running switch	9. RS485 terminal block
3. DIP switch	10. DC24V power supply terminal
4. Ethernet port	11. Module hook
5. Terminal definition	12. Module connection positioning hole
6. Removable terminal block	13. Module expansion port
	14. 35mm DIN rail

2. Indicator Description

- ① PWR: Power indicator, green. Continuous ON - Power good; OFF - Power error.
- ② RUN: Running indicator, green. Continuous ON - PLC is in running state; OFF - PLC was shutdown.
- ③ COM: Communication indicator, green. Flickering - PLC is in communicating state, the flicker frequency indicates the speed of the communication; OFF - No communication.
- ④ ERR: Error indicator, red. Continuous ON - Hardware failure; Flickering - Software failure; OFF - Normal state.

According to the different states of the Error indicator, users are recommended to take the following actions:

Reference processing mode	Instruction information classification	ERR indicator status
Normal	No errors	No light
Normal, only remind users to have locked data	PLC has data lock components	Flashing yellow: the indicator is on for 0.2s and off for 0.8s
Modify PLC hardware configuration	Software setup issues that allow the user program to continue running	Flashing yellow: the indicator is on for 0.2s and off for 0.8s
Check the module parallel bus (check the RTC battery; check the power supply of the expansion module)	Communication between modules is abnormal, and the abnormal module is automatically removed, allowing the user program to continue to run	Flashing yellow: the indicator is on for 0.8s and off for 0.2s
Re-upgrade system firmware or modify user program	The firmware is abnormal or the user program is abnormal, the user program cannot be run.	Flashing red: the indicator is on for 0.5s and off for 0.5s
Return to factory	Hardware failure, user program cannot be run	Continuous ON

3. Power Supply Specification

Item	DC Power Supply
Power Supply Voltage	DC24V -15%~+20%
Power Supply Frequency	---
Power Consumption	---
Instantaneous Surge	MAX 20A 1.5ms @24VDC
Allow instant Power Loss Time	10ms or less
Fuse	0.5A, 250VAC
5V Output Voltage (for CPU)	5V, -2%~+2%, 1.2A(MAX)
Insulation Type	No Electrical isolation
Power Protection	DC input power polarity reverse, over voltage protection

4. Environmental specifications for Product

Item	Environment Specification
Temperature/Humidity	Operating temperature:0~+55℃ Storage temperature:-25~+70℃ Humidity: 5~95%RH, No condensation
Vibration Resistance	10~57 HZ, amplitude=0.075mm, 57HZ~150HZ acceleration=1G, 10 times each for X-axis, Y-axis and Z-axis
Impact Resistance	15G, duration=11ms, 6 times each for X-axis, Y-axis and Z-axis
Interference Immunity	AC EFT:±2500V Surge:±2500V DC EFT:±2500V Surge:±1000V
Over Voltage Resistance	1500VAC/1min between AC terminal and PE terminal, 500VAC/1min between DC terminal and PE terminal
Insulation Impedance	≥5MΩ between AC terminal and all input/output points to PE terminal @500VDC
Ground	The third kind of grounding(Connecting to the ground of high voltage system is prohibited)
Operating environment	Avoid dust, moisture, corrosion, electric shock and external shocks

5. Digital Input (DI) Specification

Item	Digital Input (DI)
Input Signal	No voltage contact or NPN/PNP
Action driving	ON>3.5mA OFF<1.5mA
Input Impedance	Input Impedance≈4.3KΩ
Maximum Input Current	10mA
Reaction Time	6.4ms DEFAULT, can be configured to 0.8~51.2ms
Insulation Type	Optoelectronic isolation for each channel
Input Indication	LED's lighting indicates ON, no light indicates OFF
Power supply	MPU internal power supply:DC power supply (SINK or SOURCE) 5.3mA@24VDC

6. Digital Output (DO) Specification

Item		Output point type : Relay - R	NPN or PNP transistor output T/P
Maximum load	Resistive Load	2A/1 point, 8A/4 points COM	0.5A/1 point, 2A/4 points COM
	Inductive Load	50VA	5W/DC24V
	Lamp load	100W	12W/DC24V
Minimum Load		10mA	2mA
Voltage Specification		Below 250VAC, 30VDC	30VDC
Drive Capability		Maximum contact capacity: 5A/250VAC	1A MAX, 10 seconds
Reaction Time		Off→On 10ms, On→off 5ms	Off→On 10μs, On→Off 120μs
Insulation Type		Mechanical isolation	Optoelectronic isolation for each channel
Output Indication		LED's lighting indicates ON, no light indicates OFF	
Power Supply		MPU internal 24VDC power supply	

7. Analog Input (AI) Specification

Item	Voltage Input			Current Input
Input range	0V~+10V	0V~+5V	1V~+5V	0~20mA 4~20mA
Resolution	2.5mV	1.25mV	1.25mV	5μA
Input impedance	6MΩ			250Ω
Max input range	±13V			±30mA
Input indication	LED light means normal, dark means break OFF			
Response time	5ms/4 channel			
Digital input range	12 bits, Code range: 0~32000			
Precision	0.2% F.S			
Power supply input	MPU use internal power supply, Extension module use external power supply 24VDC ±10% 5VA			
Isolation mode	Opto-electric isolation, Non-isolation between Channel ,between analog and digital is opto-electric isolation			
Power consumption	24VDC ±20%, 100mA (Max)			

8. Analog Output (AQ) Specification

Item	Voltage Output			Current Output	
Output range	0V~ +10V	0V~+5V	1V~+5V	0~20mA	4~20mA
Resolution	2.5mV	1.25mV	1.25mV	5μA	5μA
Output load impedance	1KΩ@10V	≥500Ω@10V		≤500Ω	
Output indication	LED light means normal				
Drive capability	10mA				
Response time	3ms				
Digital output range	12 bits, Code range: 0~32000				
Precision	0.2% F.S				
Power supply input	MPU use internal power supply, Extension module use external power supply 24VDC ±10% 5VA				
Isolation mode	Opto-electric isolation, Non-isolation between Channel ,between analog and digital is opto-electric isolation				
Power consumption	24VDC ±20%, 100mA (Max)				

9. Digital Input/Output (DI/DO) Wiring

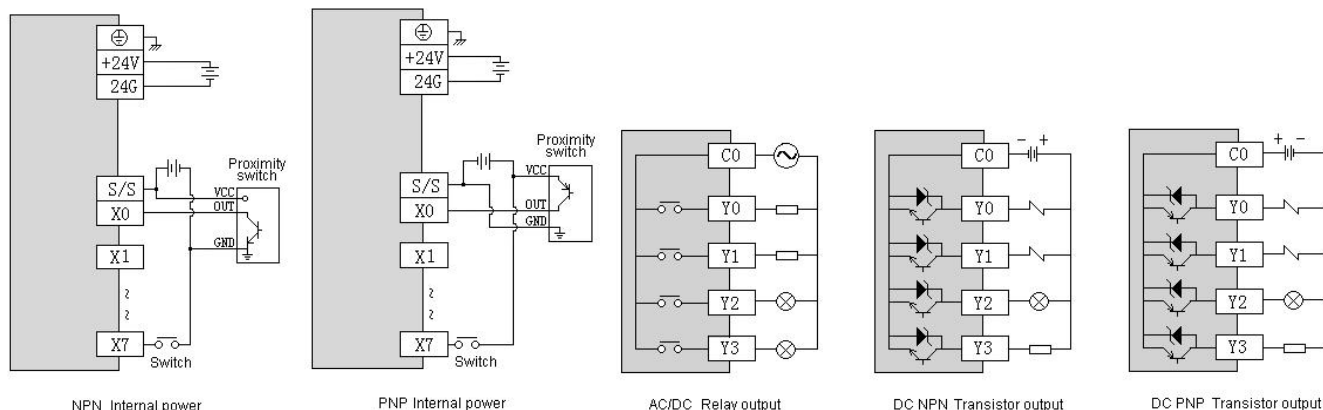

10. Analog Input (AI) Wiring Diagram

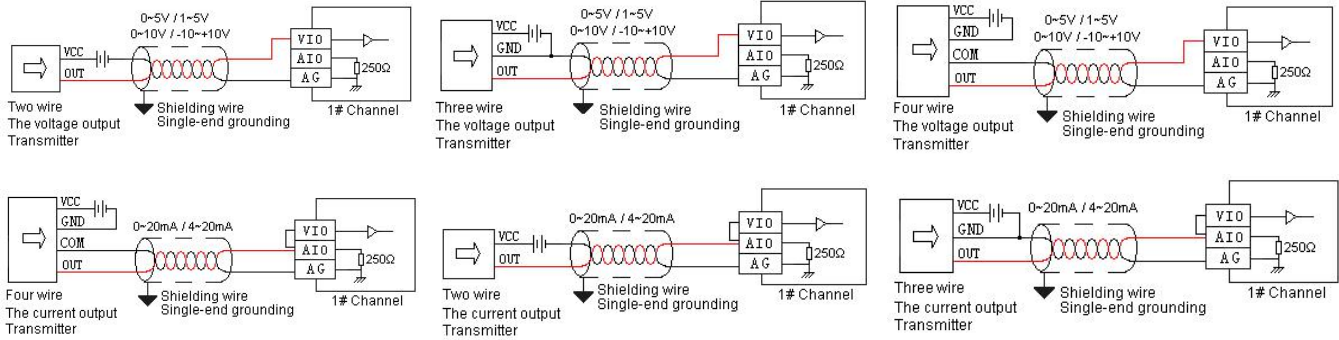

11. Analog Output (AQ) Wiring Diagram

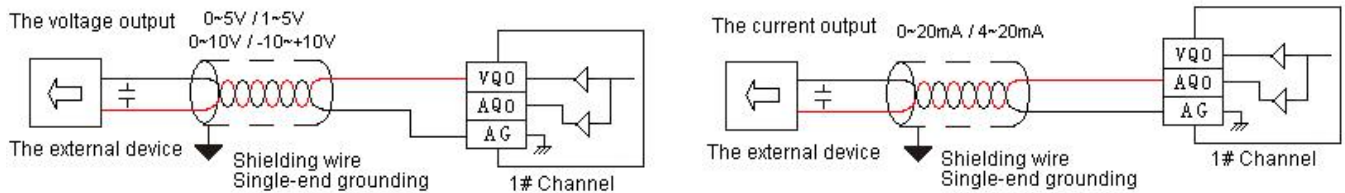

12. MPU Terminal Wiring Diagram

C0	Y0	C1	Y1	C2	Y2	C3	Y3	•	•	S/S	S/S	X0	X1	X2	X3	X4	X5	•
AC10S0R/T/P																		
C0	Y0	Y1	Y2	Y3	C4	Y4	Y5	Y6	Y7	S/S	X0	X1	X2	X3	X4	X5	X6	X7
AC16S0R/T/P																		
C0	Y0	Y1	Y2	Y3	S/S	X0	X1	X2	X3	V10	AI0	V11	AI1	AG	VQ0	AQ0	VQ1	AQ1
AC12M0R/T/P																		
C0	Y0	Y1	Y2	Y3	C4	Y4	Y5	Y6	Y7	S/S	X0	X1	X2	X3	X4	X5	X6	X7
AT16S0R/T/P																		
C0	Y0	Y1	Y2	Y3	S/S	X0	X1	X2	X3	V10	AI0	V11	AI1	AG	VQ0	AQ0	VQ1	AQ1
AT12M0R/T/P																		
C0	Y0	Y1	Y2	Y3	C4	Y4	Y5	Y6	Y7	S/S	X0	X1	X2	X3	X4	X5	X6	X7
AH16S0R/T/P																		

13. PLC Mounting and installation

The PLC should be secured to an enclosed cabinet while mounting. For heat dissipation, make sure to provide a minimum clearance of 50mm between the unit and all sides of the cabinet. (See the figure.)

PLC installation methods are divided into: rail installation and screw installation.

Rail mounting method: Use standard 35mm rail.

A series expansion module connection method

The connection between the expansion module and the host or between the expansion module and the expansion module is realized through a parallel port.

Connection method: The parallel port on the lower right side of the previous module (host or expansion module) is inserted into the parallel port on the lower left side of the next module and hooked with small card hooks on both sides. The parallel port on the

right side of this module is used for connected with the next expansion module. In this way, connect all expansion modules in sequence.

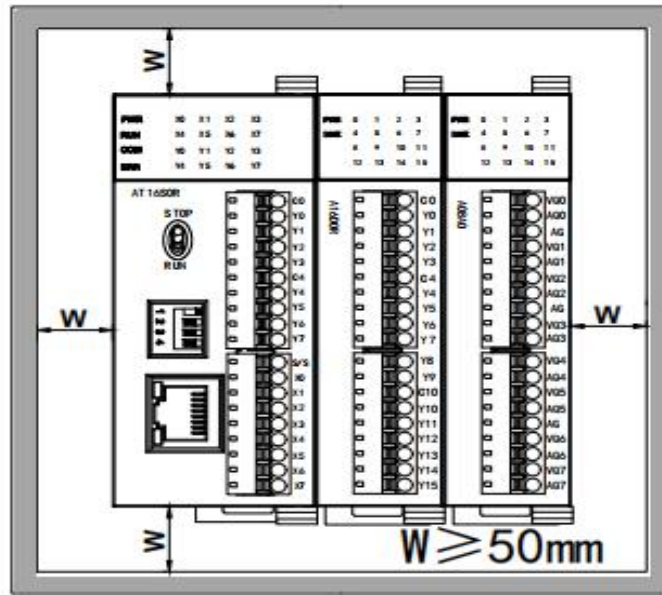

14. Address Setting

Haiwell PLC with Ethernet port, the default IP address is : 192.168.1.111, subnet mask: 255.255.255.0, gateway: 192.168.1.1. Hardware DIP dial switch address range: 1-15, the default address is 1.

If you need to set a bigger address range, you can set on the software after connection with PLC, it can be set on the PLC parameter option in the software menu by checking on the "soft address" with the range of 1-254 (the soft address is prior to the hardware dial address).



15. Power Supply Wiring

- PLC power input is DC input
- If AC110V or AC220V is connected to + 24V terminal or input point terminal, the PLC will be damaged. Users should pay special attention.